

Linear Acoustic® LA-5291

Audio Encoding, Transcoding, and Decoding for Live Dolby Atmos® Workflows

DOLBY ATMOS®



OVERVIEW

The Linear Acoustic LA-5291 Professional Audio Encoder allows you to create an exciting and immersive Dolby Atmos® experience via a Dolby Digital Plus JOC bitstream for production workflows, platforms, and delivery streams that do not require Dolby AC-4. The LA-5291 offers decoding, encoding, and transcoding to and from PCM and select Dolby® coded formats for up to 16 audio channels.

FEATURES

- Decoding from Dolby ED2 to PCM
- Transcoding from Dolby ED2 and Dolby E to Dolby Digital Plus and Dolby Digital Plus JOC
- Encoding PCM to Dolby Digital Plus and Dolby Digital Plus JOC
- 3Gb/s HD/SD-SDI and AES-3 I/O
- AES67 I/O in support of SMPTE ST 2110-30 and -31 workflows
- Optional Quad-Link 3Gb/s SDI I/O for supporting 4K video workflows, or optional MAD1 I/O (mutually exclusive options)
- Dual internal redundant auto-ranging power supplies
- Browser-based remote control

IN DEPTH

Supporting Today's Dolby Atmos Workflows

While emerging standards such as ATSC 3.0 continue to advance and provide improved immersive audio for OTA broadcast, the amount of cinematic and live content produced in Dolby Atmos continues to grow as well reaching consumers via Blu-ray Disc, satellite, cable, and streaming services. The workflow required to create, transport, and deliver that content to viewers at home can be complex, requiring the ability to work with PCM, Dolby ED2, Dolby E, Dolby Digital Plus, and Dolby Digital Plus JOC formats - tasks for which the LA-5291 was purpose-built.

Equally at Home for Contribution and Distribution

The LA-5291 integrates well into remote and OB trucks for encoding multi-channel PCM audio into Dolby Digital Plus or Dolby Digital Plus JOC for distribution. Further downstream, it can transcode Dolby ED2 and Dolby E directly to Dolby Digital Plus and Dolby Digital Plus JOC, and can encode PCM to Dolby Digital Plus and Dolby Digital Plus JOC for final distribution.

LA-5291 | Audio Encoding, Transcoding, and Decoding for Live Dolby Atmos® Workflows

End-to-End Workflow

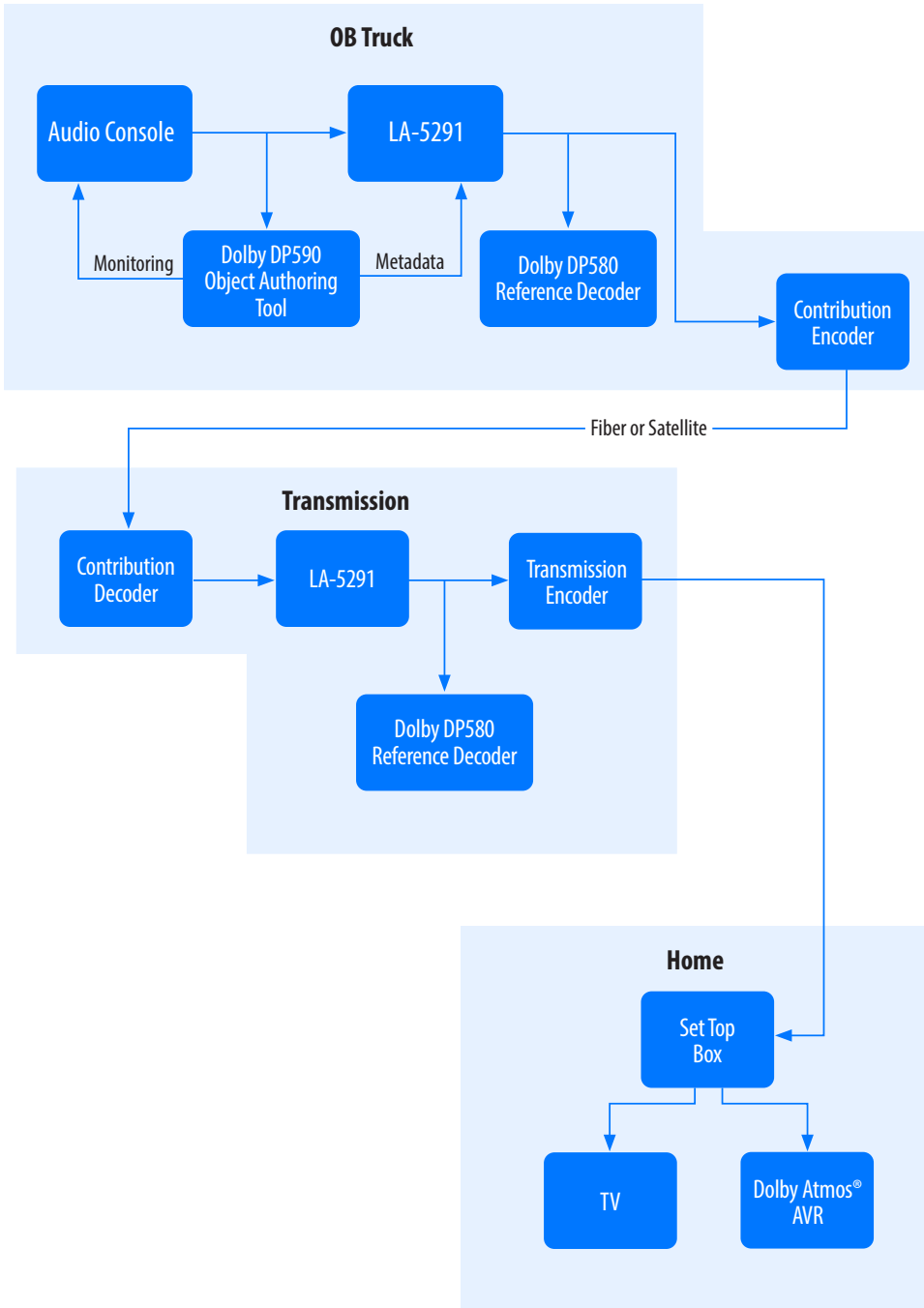

LA-5291 | Audio Encoding, Transcoding, and Decoding for Live Dolby Atmos® Workflows

OB Truck/Production Workflow

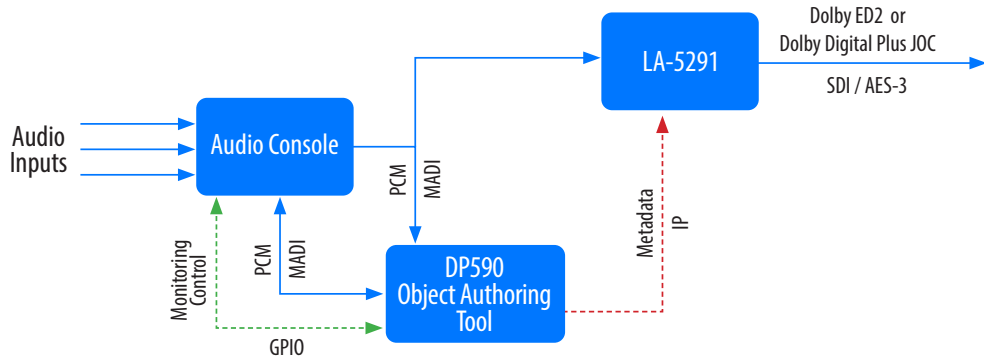

Broadcast Center Decode / Insert / Encode

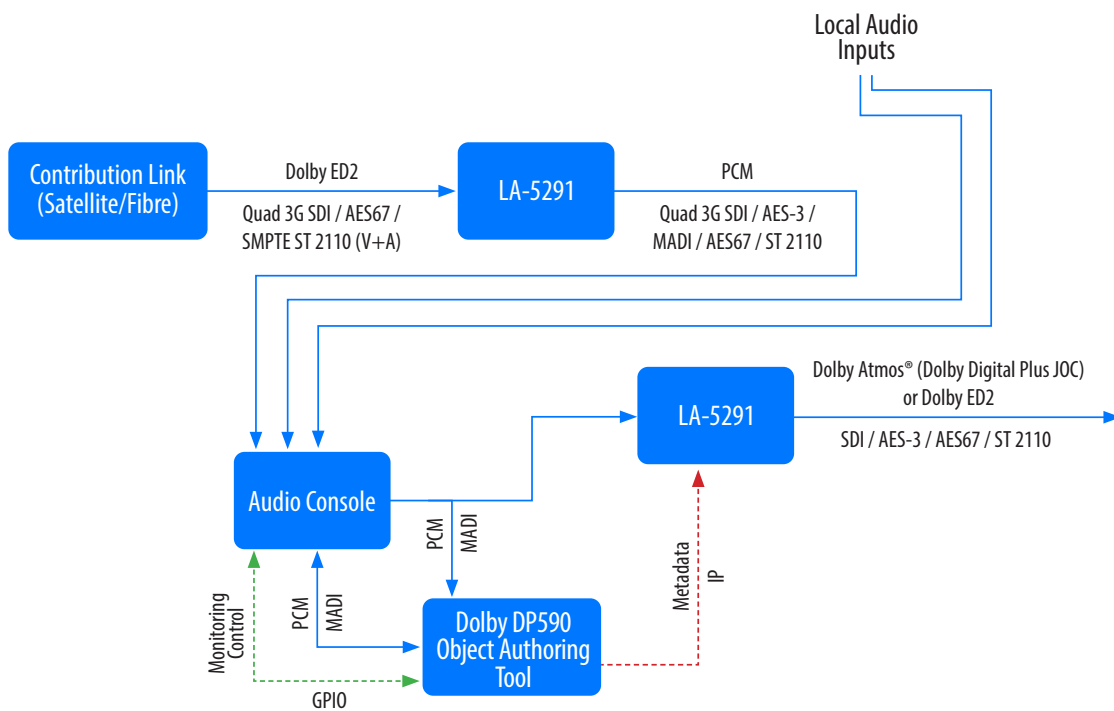

SPECIFICATIONS

Decoding

- Decoding from Dolby ED2 to PCM

Transcoding

- Transcodes Dolby ED2 and Dolby E to Dolby Digital Plus and Dolby Digital Plus JOC

Encoding

- Encodes PCM to Dolby Digital Plus and Dolby Atmos (via Dolby Digital Plus JOC)

3G HD/SD-SDI I/O

- Two independent auto-sensing 3Gb/s HD/SD-SDI inputs (SMPTE ST 425-1, 292M, and 259M), up to 1080i/60/59.94/50Hz
- Optional Quad-Link 3Gb/s SDI for 4K workflows (mutually exclusive with MADI option)

AES-3 I/O

- 5 stereo pairs via 75 Ohm BNC unbalanced female connectors, internally terminated; signal levels per SMPTE 276M/AES-3ID-2001

AES67 I/O

- 16 channels of bi-directional AES67 I/O in support of SMPTE ST 2110-30 and -31 workflows

MADI I/O

- Optional MADI I/O supports up to 16 channels for processing
- Passthrough and shuffling for up to 64 channels
- I/O via coax or optical SFP socket (SFP sold separately)
- MADI option mutually exclusive with Quad-Link SDI option

Reference

- 48kHz reference via SDI, PTP, AES-3, internal clock (standalone use only), or MADI (when MADI option is installed)
- Vref

Sample Rate/Resolution/Frequency Response

- 48kHz, 24-bit, 20Hz – 20kHz

Ethernet

- Two Gigabit RJ-45 connections – one for AES67, one for networked remote control

Parallel GPI/O Control Port

- 15-pin female D connector, 0-5V TTL levels, 5 GPI/O inputs, 5 GPI/O outputs

Power

- Dual internal redundant auto-ranging power supplies
- 95-240 VAC, 50/60 Hz, 100W maximum total

Dimensions and Weight

- 19" W x 15.5" D x 1.75" H (approximately 48.2 x 39.4 x 4.5 cm)
- Net weight: Approximately 9.0 lbs (4.08 kg)
- Shipping weight: Approximately 12.0 lbs (5.44 kg)

Regulatory

- North America – FCC and CE tested and compliant with UL-approved power supplies
- Europe – Complies with European Union Directive 2002/95/EC on the restriction of use of certain hazardous substances in electrical and electronic equipment (RoHS), as amended by Commission Decisions 2005/618/EC, 2005/717/EC, 2005/747/EC (RoHS directive), and WEEE

Warranty

- Standard Telos Alliance 2-year limited parts and labor